

SERVO SIGNAL DATA PROCESSING FOR FLYING HEIGHT CONTROL IN HARD DISK DRIVES

Uwe Boettcher, Raymond A. de Callafon, and Frank E. Talke
UCSD, Center for Magnetic Recording Research 9500 Gilman Drive, San Diego, 92093, USA

Introduction

In recent years, thermal actuated flying height control has been implemented in Hard Disk Drives (HDD) to reduce the effect of flying height variations due to manufacturing tolerances or write current introduced pole tip protrusion (Fig. 1). A stable low flying height is necessary to achieve low bit error rates (BER) [1]. Thermal flying height control is used in a “static manner” in current disk drives. The principle of thermal flying height control is based on the application of a current to a resistance heater positioned in close proximity to the read write element, thereby causing a thermal deformation of the head which causes a reduction in the static flying height at the read write element. Dynamic flying height variations of a slider over a disk are composed of repeatable and non-repeatable contributions. As the name suggests, repeatable variations of flying height occur at the same angular and radial position of the slider above the disk [2]. Thus, the question arises as to whether a thermal flying height control slider can be used to dynamically control the flying height variations between slider and disk. The objective of this paper is to study whether a thermal actuator could be used to reduce the effect that disk waviness and vibrations have on the flying height modulation of the head disk interface. Our main goal is to investigate active flying height control of a thermal slider up to the kilohertz regime.

In-situ flying height estimation

Most of the reported algorithms on in-situ flying height estimation are based on a specific data pattern that is written on the disk thereby resulting in certain harmonics in the frequency spectrum of the read signal.

Commonly used is the triple harmonics method [2,3,4] that uses the ‘111100’ data pattern to create three major harmonics. The logarithm of the ratio of the third over the first harmonic is proportional to the flying height modulation. Ratios of different harmonics other than the third and the first have also used and servo pattern might be taken into account [5]. Approaches have also been implemented based on maximum or average amplitudes [6] rather than harmonics amplitudes. Also, approaches that employ random data instead of a fixed data pattern were proposed [7].

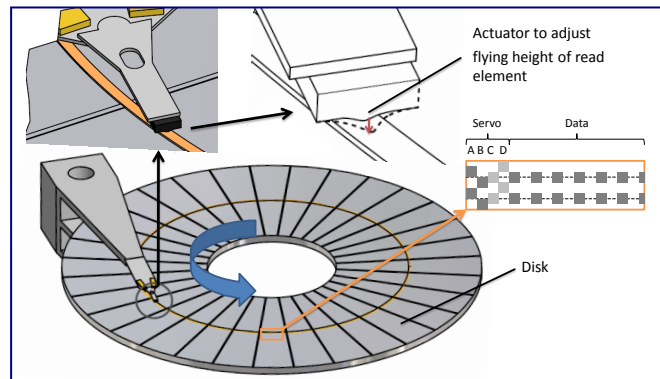

Fig.1 Flying height control in a HDD

A technique that extracts both the PES and the flying height information is reported in [8] where radially adjacent and circumferentially aligned servo bursts are generated with different frequency contributions to generate position error and flying height signals. Other techniques are the pulse width method [9], the spectral fitting method [10] and methods that estimate the flying height based on the slope of isolated pulses of the read back signal [11]. Some of these estimation algorithms embody at least one of the following disadvantages:

1. Cross-track-motion can wrongfully be detected as a change in flying height
2. The measurement can strongly depend on the radial position of the read element with respect to the disk (skew angle)
3. A particular data pattern and/or the data sector is necessary, and, thus, storage space is lost
4. The method may not be capable for perpendicular magnetic recording

Servo signal based flying height estimation

The estimation scheme proposed in this study for the measurement of the variation of flying height is based on the servo pattern written on the disk. Using the servo pattern for the estimation of flying height has a number of advantages. At every servo sector the off-track spacing is known since the position error signal (PES) is generated. Hence, the effect of cross-track motion of the head on the flying height signal can be eliminated. The servo can be an amplitude based servo or a timing based servo. Timing based servo applications have been shown to be more accurate than amplitude based counterparts [12]. The estimation of flying height variation using an amplitude based servo pattern will be shown in this study. The following assumptions are made: 1.) The change in magnetic spacing corresponds to a change in flying height which requires a constant carbon overcoat and lubricant thickness (Fig. 2), 2.) The flying height variation of adjacent servo bursts within the same servo sector is small compared to the flying height variation between adjacent servo sectors. 3.) The writing process is less sensitive to flying height variations than the reading process [4].

Based on those assumptions we can compute the change in flying height from the Wallace equation. The Fourier transform of the read back signal Φ decays exponentially with increasing distance d from the magnetic medium [13]. We can measure the signal voltage at a specific frequency in the frequency domain of two subsequent servo bursts e.g. A and B

$$\Phi_A(k, d) + \Phi_B(k, d) = (\Phi_A(k, 0) + \Phi_B(k, 0))e^{-kd}$$

where $k=2\pi/\lambda$ is the wave number. The flying height change $\Delta d=d-d_{ref}$ can be calculated from

$$\Delta d = -\frac{\lambda}{2\pi} \ln \left(\frac{\Phi_A(\lambda, d) + \Phi_B(\lambda, d)}{\Phi_A(\lambda, d_{ref}) + \Phi_B(\lambda, d_{ref})} \right) \quad (1)$$

The fluctuation of the product of the recording layer thickness and the remanent magnetization (Mrt) of the recording media [4] causes read back signal modulation, and, therefore modulations in the measured flying height. The harmonics ratio method referred to earlier decreases this effect. The proposed servo sum method estimates the flying height based on the first harmonic of the whole servo burst and is therefore insensitive to small variations in Mrt and the recording layer thickness within the burst.

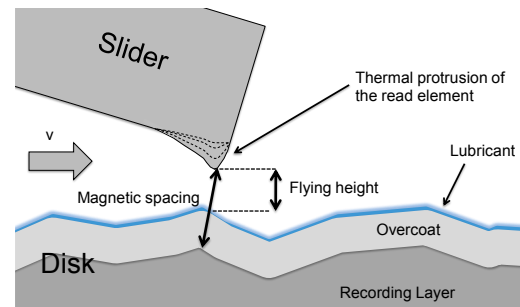

Fig. 2 Flying height definition

The cross-track characteristics of the flying height change estimate (1) are shown in Fig.3. It can be observed that the estimate is fairly insensitive to cross-track motion for about 80% of the track width. It should be noted that the shape of the curve in Fig. 3 depends strongly on the servo spacing which is assumed to be known and constant over the whole disk.

Spin stand measurements

We have performed a number of measurements using a disk head tester (MicroPhysics) and longitudinal media and heads. A simple dual servo signal with

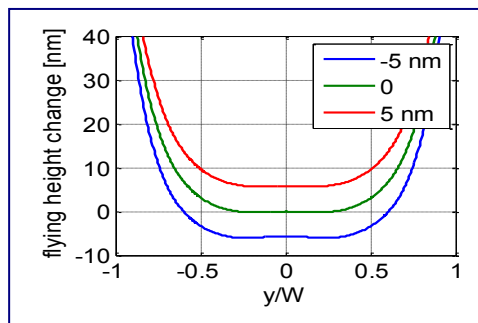

Fig. 3 Simulated cross-track characteristics

A and B bursts was written onto the disk at a track density of 130 k tracks per inch. The first harmonic of the servo was fixed at 56.25 MHz regardless of the position of the read element. The read back signal was captured using a 2GS/s digitizer. The results for one revolution are shown in Fig. 4. Here, the PES was computed by

$$PES = \frac{A-B}{A+B} \quad (2)$$

where A and B refers to the first harmonics of the A and B bursts, respectively, and Δd is computed using (1). The power applied to the thermal actuator was varied from 0 (blue curve) to approx. 100mW (red curve). From Fig. 4 it can be observed that the estimated flying height decreases as the heater power increases. More importantly, we observe that the dynamic variation of Δd stays relatively constant.

It is noted that ‘written-in’ variations in servo burst spacing are anticipated to influence the estimation of Δd .

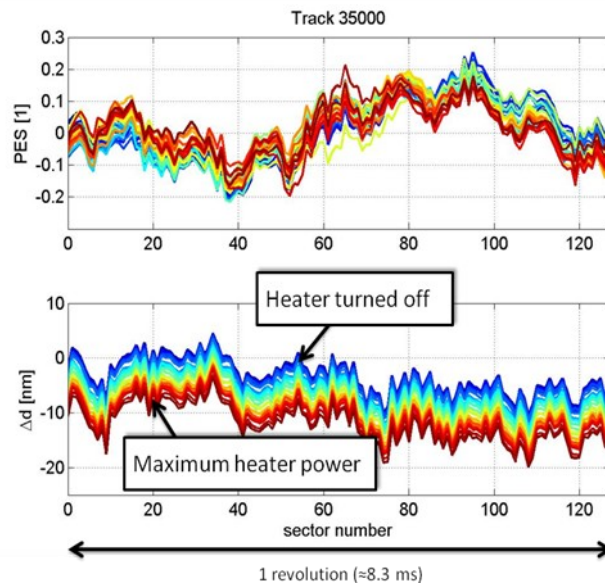

Fig. 4 PES and flying height modulation for one revolution at different heater power levels at $r=30\text{mm}$

Conclusions

A flying height estimation technique based on the first harmonics of the servo signal has been proposed. Both simulations and measurements show high sensitivity of the estimate to a change in flying height and a small sensitivity to cross-track motion of the read element. The estimation is strongly influenced by the accuracy of the servo writing process, i.e., by the cross-track spacing between the A and B burst in each servo sector.

References

- [1] Y. Tang, S-Y. Hong, N-Y. Kim, and X. Che, "Overview of fly height control applications in perpendicular magnetic recording," *IEEE Trans. on Magn.*, Vol. 43, No. 2, pp. 709-714, 2007.
- [2] J. Xu, Y. Shimuzu, and L. Su, "Drive level measurement of flying height modulation and control of slider disk contact," *Tribology Letters*, Vol. 24, No. 2, pp.159-62, 2006.
- [3] B. Liu and Z. Yuan, "Tribo-magnetics and nanometer spaced head-disk systems," *Asia-Pacific Magnetic Recording Conference*, TB5/1-TB5/2, 2000.
- [4] [4] Z-M. Yuan, B. Liu, W. Zhang, and S-B. Hu, "Engineering study of triple-harmonic method for in situ characterization of head-disk spacing," *Journal of Magnetism and Magnetic Materials*, Vol. 239, No. 1-3, pp. 367-70, 2002.
- [5] US Patent Application 20090153996
- [6] US Patent 7522360
- [7] Q-H. Zeng and M. Chen, "Flying height modulation estimation from pseudorandom read-back signal in disk drives," *IEEE Trans. on Magn.*, Vol. 39, No. 5, pp. 2417-19, 2003.
- [8] US Patent 7253984
- [9] K.B. Klaassen and J.C.L. van Pepper, "Slider-disk clearance measurements in magnetic disk drives using the readback transducer," *IEEE Trans. on Instr. and Measurement*, Vol. 43, No. 2. pp. 121-26, 1994.
- [10] C. Fu, A. Takeo, and H. N. Bertram, "Technique to obtain head-medium magnetic spacing in a disk drive," *J. Appl. Phys.*, Vol. 97, No. 10, pp. 10P107-1-10P107-3, 2007.
- [11] US Patent 6288856
- [12] Y. Han, and R.A. de Callafon, "Evaluating track - following servo performance of high-density hard disk drives using patterned media," *IEEE Trans. on Magn.*, Vol. 45, No. 12, pp. 5352-59, 2009.
- [13] Bertram, N., 1994, *Theory of Magnetic Recording*, Cambridge University Press, p.40